



Global Yeou Diann Electric Industrial Co., Ltd

No. 378, Kaisyuan 4th Rd., Cianjhen District,

Kaohsiung City, 806, Taiwan(R.O.C)

TEL: 886-7-813-2957 FAX: 886-7-813-2967~68

Test Verification of Conformity

On the basis of the tests undertaken, the samples(s) of the below product have been found to comply with the essential requirements of the referenced specifications at the time of the tests were carried out.

Applicant Name & Address : GLOBAL YEOU DIANN ELECTRIC INDUSTRIAL CO.,LTD.
No.378,Kaisyuan 4th Rd., Cianjhen District, Kaohsiung City
806, Taiwan

Product(s) Tested : SWITCHING ADAPTER

Brand name : AMIGO

Ratings and principal Characteristics : Input: 100-240VAC, 50/60Hz, 0.8A
Output: 12Vdc, 2.0A

Model(s) :AMS200-1202000FV, AMS200-1202000FB, AMS200-1202000F

Relevant : COMMISSION REGULATION (EU) 2019/1782 of 1 October 2019 laying down ecodesign requirements for external power supplies pursuant to Directive 2009/125/EC of the European Parliament and of the Council and repealing Commission Regulation (EC) No 278/2009.

NOTE: This verification is part of the full test report(s) and should be read in conjunction with it.

Prepared by:

Signature: Qiongfang Zheng

Print: Qiongfang Zheng

Date: 2019-12-20

Approved by:

Signature: Sunrise Hsiao

Print: Sunrise Hsiao

Date: 2019-12-20



Global Yeou Diann Electric Industrial Co., Ltd

No. 378, Kaisyuan 4th Rd., Cianjhen District,

Kaohsiung City, 806, Taiwan(R.O.C)

TEL: 886-7-813-2957 FAX: 886-7-813-2967~68

External Power Supplies Energy Efficiency Test Report

Applicant:	GLOBAL YEOU DIANN ELECTRIC INDUSTRIAL CO.,LTD.
Address:	No.378,Kaisyuan 4th Rd., Cianjhen District, Kaohsiung City 806, Taiwan
Product:	SWITCHING ADAPTER
Trade Name:	AMIGO
Model:	AMS200-1202000FV, AMS200-1202000FB,AMS200-1202000F
Rating:	12Vdc, 2.0A
Input:	100-240VAC, 50/60Hz, 0.8A
Output:	12Vdc, 2.0A
Tested by (printed name and signature) :	Dingsheng Lu <i>Dingsheng Lu</i>
Reviewed by (printed name and signature) :	Qiongfang Zheng <i>Qiongfang zheng</i>
Approved by (printed name and signature) :	Sunrise Hsiao <i>Sunrise Hsiao</i>
Date of issue:	2019-12-20
Testing procedure:	EN 50563:2011+A1:2013: External a.c. - d.c. - a.c. power supplies - Determination of no-load power and average efficiency of active modes. EN 50564:2011: Electrical and electronic household and office equipment- Measurement of low power consumption.
Conclusion:	From the results of our testing, we are hereby declare that the product COMPLY WITH COMMISSION REGULATION (EU) 2019/1782 of 1 October 2019 laying down ecodesign requirements for external power supplies pursuant to Directive 2009/125/EC of the European Parliament and of the Council and repealing Commission Regulation (EC) No 278/2009.



Test program and conditions:

1. All tests was carried out in a room with an air speed immediately surrounding the UUT of ≤ 0.5 m/s.
2. The ambient temperature was maintained at 25 °C throughout the test.
3. Measurements were mode for supply voltage of 115V/60Hz and 230V/50Hz.
4. The load conditions specified in Table 1 shall be achieved by using a resistive load. The resistive load may be a variable resistor, an electronic test load, or a combination thereof, having a power factor of 0.95 to 1. When an electronic load is used, the constant current mode is used.
5. Test set-up according following figure 1.

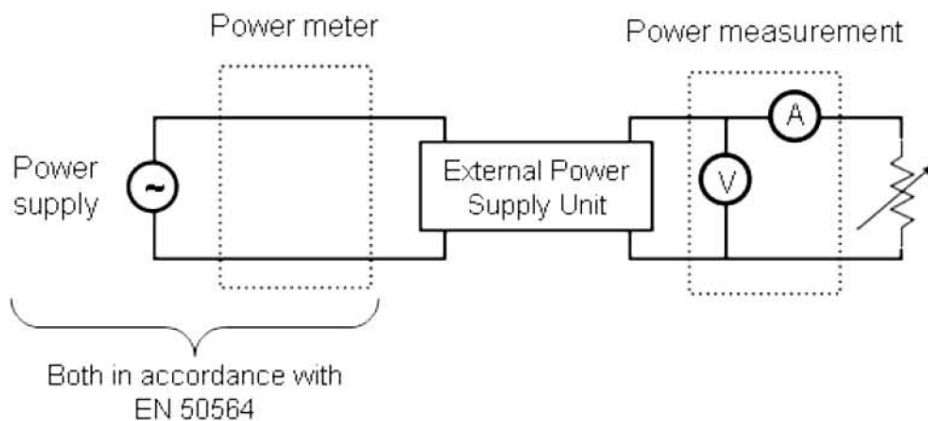

Figure 1

6. Testing sequence:

The tests shall be conducted as follows:

- a) Using the set-up in figure 1 apply load condition as specified in Table 1.
- b) The output of the EPS shall be maintained at load condition 1 for at least 30 minutes, this is the warm-up period. After this warm-up period the AC input power is monitored for a period of 5 minutes to assess stability. If the input power level does not change by more than 5% during these 5 min the measurement is considered to be stable and the measurements are recorded at the end of the 5 minute period. If the AC input power is not stable over a 5 minute period, stability shall be determined in accordance with EN 50564:2011, 5.3. If load



Global Yeou Diann Electric Industrial Co., Ltd
No. 378, Kaisyuan 4th Rd., Cianjhen District,
Kaohsiung City, 806, Taiwan(R.O.C)
TEL: 886-7-813-2957 FAX: 886-7-813-2967~68

- condition 1 cannot be maintained for either warm-up period or the stability period then compliance with this standard cannot be determined.
- c) Immediately subsequent to b) load conditions 2 through 5 are measured in sequence each with a 5 minute period for determining stability. If is not necessary to repeat the warm-up period unless the EPS is not stable within each of the 5 minute periods. If AC input is not stable over a 5 minute period, stability shall be determined in accordance with EN 50564:2011, 5.3. When it is not possible to immediately follow the preceding test condition a warm-up period of at least 30 min shall be introduced using the relevant load condition.
- d) If the external power supply has a user-selectable output voltage, the above sequence is conducted first with the highest output voltage setting and then the sequence is repeated with the lowest voltage setting.
7. Power consumption of the UUT at each Load Condition 1-5 is the difference between the DC output power (W) at that Load Condition and the AC input power (W) at that Load Condition. The power consumption of Load Condition 6 (no load) is equal to the AC input power (W) at that Load Condition.

TABLE 1—LOADING CONDITIONS FOR UNIT UNDER TEST

Loading Condition 1	100% of Derated Nameplate Output Current $\pm 2\%$.
Loading Condition 2	75% of Derated Nameplate Output Current $\pm 2\%$.
Loading Condition 3	50% of Derated Nameplate Output Current $\pm 2\%$.
Loading Condition 4	25% of Derated Nameplate Output Current $\pm 2\%$.
Loading Condition 5	10% of Derated Nameplate Output Current $\pm 2\%$.
Loading Condition 6	0%.



Global Yeou Diann Electric Industrial Co., Ltd
 No. 378, Kaisyuan 4th Rd., Cianjhen District,
 Kaohsiung City, 806, Taiwan(R.O.C)
 TEL: 886-7-813-2957 FAX: 886-7-813-2967~68

Test data:

Load conditions	No load	Active Power Values				
115Vac 60Hz	0%	10%	25%	50%	75%	100%
Total Harmonic Distortion(THD)	0.17	0.55	0.22	0.34	0.46	0.51
RMS Input Power (W)	0.041	2.775	6.615	13.425	20.475	27.740
True Power Factor (W/VA)	0.05	0.34	0.49	0.53	0.55	0.57
Output Voltage (Vdc)	11.92	11.81	11.84	11.85	11.93	12.00
Output Current (mA)	--	200	500	1000	1500	2000
Active Output Power (W)	--	2.362	5.920	11.850	17.895	24.000
Power Consumed (W)	0.041	0.404	0.695	1.575	2.580	3.740
Efficiency (%)	/	85.12	89.49	88.26	87.39	86.51
Average Efficiency(%)	/	/	87.91			
Load conditions	No load	Active Power Values				
230Vac 50Hz	0%	10%	25%	50%	75%	100%
Total Harmonic Distortion(THD)	0.54	0.55	0.56	0.57	0.62	0.63
RMS Input Power (W)	0.064	2.766	6.650	13.340	20.283	27.455
True Power Factor (W/VA)	0.02	0.34	0.40	0.44	0.47	0.48
Output Voltage (Vdc)	11.89	11.81	11.83	11.87	11.94	12.04
Output Current (mA)	--	200	500	1000	1500	2000
Active Output Power (W)	--	2.362	5.915	11.870	17.910	24.080
Power Consumed (W)	0.064	0.404	0.735	1.47	2.373	3.375
Efficiency (%)	/	85.39	88.94	88.98	88.30	87.70
Average Efficiency(%)	/	/	88.48			

TEST RESULTS:

Test item	Required	115V, 60Hz	230V, 50Hz	Verdict
No load power (W)	$\leq 0.10W$	0.041	0.064	Pass
Average efficiency (%) ¹⁾	≥ 86.21	87.91	88.48	Pass
Efficiency of 10% full load (%)	N/A	0.041	0.064	Ref.only
Complies with performance mark	VI			

Note: ¹⁾ the average efficiency of 25%, 50%, 75% and 100% full load.



Global Yeou Diann Electric Industrial Co., Ltd
 No. 378, Kaisyuan 4th Rd., Cianjhen District,
 Kaohsiung City, 806, Taiwan(R.O.C)
 TEL: 886-7-813-2957 FAX: 886-7-813-2967~68

THE LIMITS FOR EXTERNAL POWER SUPPLY:

Single-Voltage External Power Supply, Basic-Voltage			
Nameplate Output Power (P_{out})	Minimum Average Efficiency in Active Mode	Maximum Power in No-Load Mode [W]	
		AC-AC	AC-DC
$P_{out} \leq 1W$	$\geq 0.5 \times P_{out} + 0.16$	≤ 0.210	≤ 0.100
$1W < P_{out} \leq 49W$	$\geq 0.071 \times \ln(P_{out}) - 0.0014 \times P_{out} + 0.67$	≤ 0.210	≤ 0.100
$49W < P_{out}$	≥ 0.880	≤ 0.210	≤ 0.210
Single-Voltage External Power Supply, Low-Voltage			
Nameplate Output Power (P_{out})	Minimum Average Efficiency in Active Mode	Maximum Power in No-Load Mode [W]	
$P_{out} \leq 1W$	$\geq 0.517 \times P_{out} + 0.087$	≤ 0.100	
$1W < P_{out} \leq 49W$	$\geq 0.0834 \times \ln(P_{out}) - 0.0014 \times P_{out} + 0.609$	≤ 0.100	
$49W < P_{out}$	≥ 0.870	≤ 0.210	
Multiple-Voltage External Power Supply			
Nameplate Output Power (P_{out})	Minimum Average Efficiency in Active Mode	Maximum Power in No-Load Mode [W]	
$P_{out} \leq 1W$	$\geq 0.497 \times P_{out} + 0.067$	≤ 0.300	
$1W < P_{out} \leq 49W$	$\geq 0.075 \times \ln(P_{out}) + 0.561$	≤ 0.300	
$P_{out} > 49W$	≥ 0.860	≤ 0.300	

Note:

Single-voltage external AC-DC power supply means an external power supply that is designed to convert line voltage AC into lower-voltage DC output and is able to convert to only one DC output voltage at a time.

Single-voltage external AC-AC power supply means an external power supply that is designed to convert line voltage AC into lower-voltage AC output and is able to convert to only one AC output voltage at a time.

Low-voltage external power supply means an external power supply with a nameplate output voltage less than 6 volts and nameplate output current greater than or equal to 550 milliamps. Basic-voltage external power supply means an external power supply that is not a low-voltage power supply.



Global Yeou Diann Electric Industrial Co., Ltd
No. 378, Kaisyuan 4th Rd., Cianjhen District,
Kaohsiung City, 806, Taiwan(R.O.C)
TEL: 886-7-813-2957 FAX: 886-7-813-2967~68

Equipment List:

Equipment Name	Manufacturer	Model	Reg. No.	Cal. Date	Next Cal.
AC Source	GVERFINE	GK10010	RD-354	2019.1.2	2020.1.1
Digital Power Meter	YOKOGAWA	WT310E	RD-339-12	2019.7.16	2020.7.15
DC Electronic Load	ITECH	HT3150+	TQC-0228	2019.2.2	2020.2.1